

1
ALL INFORMATION CONTAINED IN THIS DOCUMENT SHOULD BE USED FOR REFERENCE PURPOSES ONLY & ARE SUBJECT TO CHANGE WITHOUT PRIOR NOTIFICATION. ALSO, THIS DOCUMENT IS CONSIDERED PROPRIETARY & THE SOLE PROPERTY OF CRYOMECH, INC. & SHOULD NOT BE REPRODUCED IN ANY MANNER WITHOUT PRIOR WRITTEN APPROVAL.

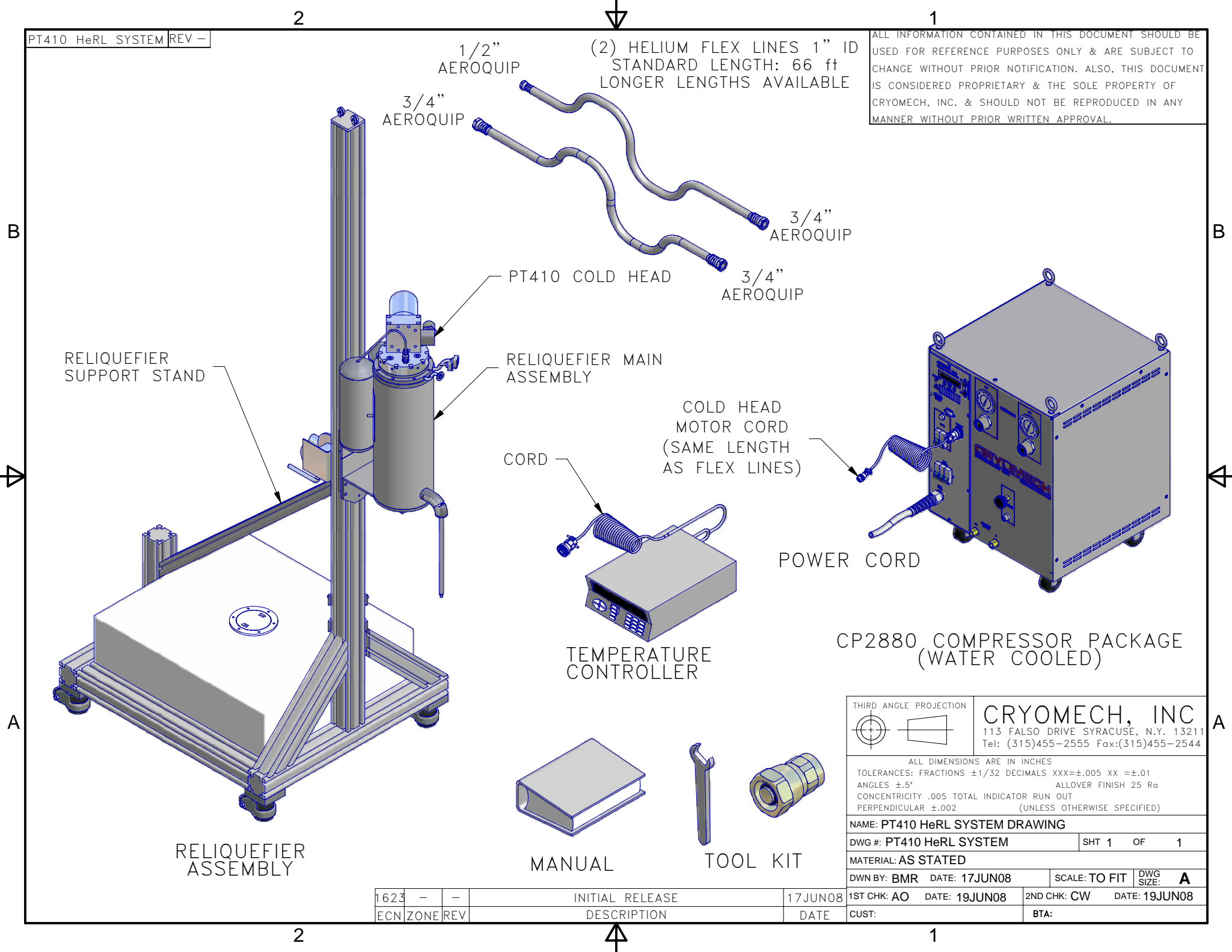

CP2880 COMPRESSOR PACKAGE (WATER COOLED)

THIRD ANGLE PROJECTION

CRYOMECH, INC
113 FALSO DRIVE SYRACUSE, N.Y. 13211
Tel: (315)455-2555 Fax:(315)455-2544

ALL DIMENSIONS ARE IN INCHES
TOLERANCES: FRACTIONS ±1/32 DECIMALS XXX=±.005 XX =±.01
ANGLES ±.5° ALLOVER FINISH 25 Ra
CONCENTRICITY .005 TOTAL INDICATOR RUN OUT
PERPENDICULAR ±.002 (UNLESS OTHERWISE SPECIFIED)

NAME: PT410 HeRL SYSTEM DRAWING			
DWG #: PT410 HeRL SYSTEM		SHT 1 OF 1	
MATERIAL: AS STATED			
DWN BY: BMR	DATE: 17JUN08	SCALE: TO FIT	DWG SIZE: A
1ST CHK: AO		DATE: 19JUN08	2ND CHK: CW
DATE: 19JUN08		DATE: 19JUN08	
CUST:		BTA:	

1623	-	-	INITIAL RELEASE	17JUN08
ECN	ZONE	REV	DESCRIPTION	DATE

RELIQUEFIER ASSEMBLY

MANUAL

TOOL KIT